

ELECTRONICS ENGINEERING

Communication Systems

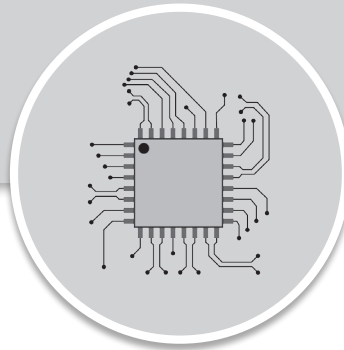

Comprehensive Theory
with Solved Examples and Practice Questions





MADE EASY Publications Pvt. Ltd.

Corporate Office: 44-A/4, Kalu Sarai (Near Hauz Khas Metro Station), New Delhi-110016 | **Ph. :** 9021300500

Email : infomep@madeeasy.in | **Web :** www.madeeasypublications.org

Communication Systems

Copyright © by MADE EASY Publications Pvt. Ltd.
All rights are reserved. No part of this publication may be reproduced, stored in or introduced into a retrieval system, or transmitted in any form or by any means (electronic, mechanical, photo-copying, recording or otherwise), without the prior written permission of the above mentioned publisher of this book.

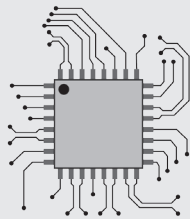

MADE EASY Publications Pvt. Ltd. has taken due care in collecting the data and providing the solutions, before publishing this book. In spite of this, if any inaccuracy or printing error occurs then **MADE EASY Publications Pvt. Ltd.** owes no responsibility. We will be grateful if you could point out any such error. Your suggestions will be appreciated.

EDITIONS

- First Edition : 2015
- Second Edition : 2016
- Third Edition : 2017
- Fourth Edition : 2018
- Fifth Edition : 2019
- Sixth Edition : 2020
- Seventh Edition : 2021
- Eighth Edition : 2022
- Ninth Edition : 2023
- Tenth Edition : 2024
- Eleventh Edition : 2025
- Twelfth Edition : 2026**

CONTENTS

Communication Systems

CHAPTER 1

Introduction to Communication Systems 1-24

1.1	Historical Sketch	1
1.2	Why Study Communication.....	1
1.3	What is Communication.....	1
1.4	Communication Model	2
1.5	Modes of Communication.....	3
1.6	Types of Modulation.....	4
1.7	An Exam Oriented Approach	5
1.8	Important Fourier Transform.....	5
1.9	Transmission of Signals through Linear Time-Invariant Systems	6
1.10	Ideal Filters	9
1.11	Hilbert Transform.....	10
1.12	Pre-envelopes	15
1.13	Complex Envelopes of Band-Pass Signals	17
1.14	Canonical Representation of Band-Pass Signals	18
1.15	Complex Low-Pass Representations of Band-Pass Systems.....	19
	<i>Objective Brain Teasers</i>	20
	<i>Conventional Brain Teasers</i>	22

CHAPTER 2

Theory of Random Variable and Noise 25-80

2.1	Randomness in the Real World.....	25
2.2	Random Experiments.....	25
2.3	Conditional Probability	27
2.4	Statistical Independence	28
2.5	Bernoulli Trials.....	29
2.6	Random Variable.....	29

2.7	Distribution Function CDF Specifies the Probability of a RV 'X' Taking Values upto 'X'.....	30
2.8	Probability Density Function.....	30
2.9	Some Special Random Variable Distribution.....	33
2.10	Mean, Variance and Moment	36
2.11	Multiple Random Variables	39
2.12	Functions of Random Variables.....	42
2.13	Statistical Independence	45
2.14	Distribution and Density of A Sum of Random Variables.....	46
2.15	Central Limit Theorem	52
2.16	Stochastic Processes or Random Processes.....	52
2.17	Ergodic Processes	56
2.18	Transmission of a Weakly Stationary Process through a Linear Time-Invariant Filter	57
2.19	Power Spectral Density of a Weakly Stationary Process.....	58
2.20	Noise	61
2.21	Noise Calculations.....	65
2.22	Noise Figure.....	67
2.23	Ideal Low-pass Filtered White Noise	71
2.24	Narrowband Noise	73
	<i>Objective Brain Teasers</i>	77
	<i>Conventional Brain Teasers</i>	80

CHAPTER 3

Amplitude Modulation 81-119

3.1	Amplitude Modulation.....	81
3.2	Single Tone Amplitude Modulation.....	85
3.3	Power Relations in AM	88

3.4	Modulation by a Multiple Single Tone Signals (Multi-Tone Modulation)	90
3.5	Generation of AM Waves.....	93
3.6	Double-Sideband Suppressed-Carrier Modulation [DSB-SC]	100
3.7	Single Side-Band.....	108
3.8	Vestigial Side-band Modulation (VSB).....	113
3.9	Independent Single Sideband (ISB)	114
	<i>Objective Brain Teasers</i>	116
	<i>Conventional Brain Teasers</i>	117

CHAPTER 4

Angle Modulation 120-152

4.1	Time Domain Description of Angle Modulation.....	120
4.2	Single-Tone Frequency Modulation	123
4.3	Spectrum Analysis of Sinusoidal FM wave	127
4.4	Types of Frequency Modulation (FM)	129
4.5	Generation of Frequency Modulation Waves.....	131
4.6	Demodulation of Frequency Modulation Waves	135
4.7	Phase-Locked Loop (PLL).....	141
4.8	Limitation of FM Waves	145
4.9	Comparison between Amplitude Modulation and Frequency Modulation	147
4.10	Comparison between FM and PM	148
	<i>Objective Brain Teasers</i>	148
	<i>Conventional Brain Teasers</i>	149

CHAPTER 5

AM Transmitters and Receivers..... 153-181

5.1	Transmitter	153
5.2	Receivers.....	155
5.3	Preemphasis and Deemphasis.....	165
5.4	Noise Figure of the Receiver	167
5.5	Noise Performance of Continuous Wave Modulation ...	168
5.6	Threshold Effect	178
5.7	FM Capture Effect	179
	<i>Objective Brain Teasers</i>	179
	<i>Conventional Brain Teasers</i>	181

CHAPTER 6

Pulse Modulation..... 182-230

6.1	Analog Communication Versus Digital Communication	182
6.2	Sampling Theory.....	183
6.3	Pulse Amplitude Modulation	189
6.4	Pulse Width Modulation.....	190
6.5	Pulse Position Modulation	192
6.6	PCM (Pulse Code Modulation)	194
6.7	Companding	198
6.8	Mathematical Analysis of PCM	200
6.9	Noise in PCM	207
6.10	Encoding in PCM.....	207
6.11	Intersymbol Interference.....	210
6.12	Merits and Demerits of PCM.....	215
6.13	Differential Pulse Code Modulation.....	215
6.14	Delta Modulation.....	216
6.15	Adaptive Delta Modulation (ADM).....	220
6.16	Multiplexing	221
	<i>Objective Brain Teasers</i>	227
	<i>Conventional Brain Teasers</i>	230

CHAPTER 7

Data Transmission Schemes231-267

7.1	Geometric Representation of Signal	232
7.2	Schwarz Inequality.....	235
7.3	Digital Modulation Schemes	237
7.4	Amplitude Shift Keying (ASK)	237
7.5	Frequency Shift Keying (FSK)	240
7.6	Phase Shift Keying.....	244
7.7	Quadrature Phase Shift Keying.....	247
7.8	Quadrature Amplitude Modulation.....	251
7.9	Differential Phase Shift Keying (DPSK).....	254
7.10	Minimum Shift Keying(MSK)	256
	<i>Objective Brain Teasers</i>	259
	<i>Conventional Brain Teasers</i>	263

CHAPTER 8**Optimum Receivers for AWGN Channels... 268-299**

8.1	Detection of Signal in Noise	269
8.2	Optimum Detection in a Binary Communication System Using MAP Criteria	270
8.3	Probability of Error	273
8.4	Matched Filter	273
8.5	Generalized Probability of Error Expression of Digital Signalling Schemes	277
8.6	Probability of Error for Binary Signalling Schemes...	281
8.7	Probability of Error of QPSK	285
	<i>Objective Brain Teasers</i>	287
	<i>Conventional Brain Teasers</i>	291

CHAPTER 9**Information Theory and Coding..... 300-345**

9.1	Need of Information Theory	300
9.2	Information.....	301
9.3	Entropy	302
9.4	Discrete Memoryless Channels	305
9.5	Special Channels.....	306
9.6	Mutual Information.....	309
9.7	Channel Capacity.....	311

9.8	Entropy of Continuous Channel.....	313
9.9	Additive White Gaussian Noise Channel (AWGN)	313
9.10	Source Coding	314
9.11	Entropy Coding	316
9.12	Channel Coding Theorem	319
9.13	Error Control Coding	320
9.14	Linear Code.....	324
9.15	Cyclic Redundancy Checks (CRC).....	336
	<i>Objective Brain Teasers</i>	338
	<i>Conventional Brain Teasers</i>	342

CHAPTER 10**Multiple Access Technique
and Communication Standards 346-361**

10.1	Multiple Access Technique.....	346
10.2	Frequency Division Multiple Access (FDMA)	347
10.3	Time Division Multiple Access (TDMA)	348
10.4	Code Division Multiple Access (CDMA)	351
10.5	Standards of Mobile Communication System	357
10.6	Global System for Mobile Communications (GSM).....	359



Introduction to Communication Systems

1.1 HISTORICAL SKETCH

The development of communication technology has proceeded in step with the development of electronic technology as a whole. For example, the demonstration of telegraphy by Joseph Henry in 1832 and by Samuel F.B. Morse in 1838 followed hard on the discovery of electromagnetism by Oersted and Ampere early in 1820's. Similarly, Hertz's verification late in the 1880's of Maxwell's postulation (1873) predicting the wireless propagation of electromagnetic energy led within 10 years of the radio-telegraph experiments of Marconi and Popov. The invention of diode by Flaming in 1904 and of triode by deforest in 1906 made possible the rapid development of long distance telephony, both by radio and wireless.

1.2 WHY STUDY COMMUNICATION

The rapidly changing face of technology necessitates learning of new technology. Today the question is no longer in the field of invention but of innovation. The question today in the twenty first century is not how to transmit data from point A to point B but how efficiently can we do it. To be able to answer this question, first we should be able to diagnose the problem. This can be done only by studying communication from the beginning to its modern form.

1.3 WHAT IS COMMUNICATION

In the most fundamental sense, communication involves implicitly the transmission of information from one point to another through a succession of processes, as described here:

1. The generation of a message signal: voice, music, picture, or computer data.
2. The description of that message signal with a certain measure of precisions, by a set of symbols: electrical, audio, or visual.
3. The encoding of these symbols in a form that is suitable for transmission over a physical medium of interest.
4. The transmission of the encoded symbols to the desired destination.
5. The decoding of the reproduction of the original symbols.
6. The re-creation of the original message signal, with a definable degradation in quality; the degradation is caused by imperfections in the system.

There are, of course, many other forms of communication that do not directly involve the human mind in real time. For example, in computer communications involving communication between two or more computers, human decisions may enter only in setting up the programs or commands for the computer, or in monitoring the results.

1.4 COMMUNICATION MODEL

The study of communication becomes easier, if we break the whole subject of communication in parts and then study it part by part. The whole idea of presenting the model of communication is to analyse the key concepts used in communication in isolated parts and then combining them to form the complete picture.

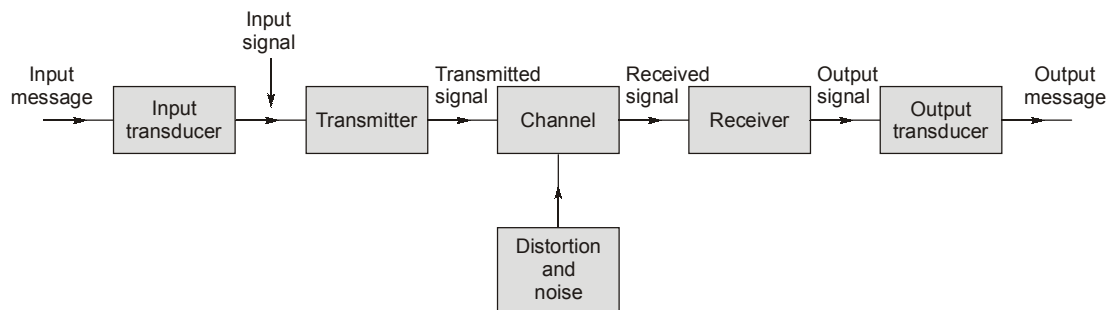

Figure : Model of communication system

Source: The source originates a message, such as a human voice, a television picture, an e-mail message, or data. If the data is non-electric (e.g., human voice, e-mail text, television video), it must be converted by an **input transducer** into an electric waveform referred to as the **baseband signal** or **message signal** through physical devices such as a microphone, a computer keyboard or a CCD camera.

Transmitter: The transmitter modifies the baseband signal for efficient transmission. The transmitter may consist of one or more subsystems: an A/D converter, an encoder and a modulator. Similarly, the receiver may consist of a demodulator, a decoder and a D/A converter.

Channel: The channel is a medium of choice that can carry the electric signals at the transmitter output over a distance. A typical channel can be a pair of twisted copper wires (telephone and DSL), coaxial cable (television and internet), an optical fibre or a radio link. Channel may be of two types.

1. **Physical channel:** When there is a physical connection between the transmitter and receiver through wires. eg. coaxial cable.
2. **Wireless channel:** When no physical channel is present and transmission is through air. eg. mobile communication.

It is inevitable that the signal will deteriorate during the process of transmission and reception as a result of some distortion in the system, or because of the introduction of noise, which is unwanted energy, usually of random character, present in a transmission system, due to a variety of causes. Since noise will be received together with the signal, it places a limitation on the transmission system as a whole. When noise is severe, it may mask a given signal so much that the signal becomes undetectable and therefore useless. Noise may interfere with signal at any point in a communications system, but it will have its greatest effect when the signal is weakest. This means that noise in the channel or at the input to the receiver is the most noticeable.

Receiver: The receiver reprocesses the signal received from the channel by reversing the signal modifications made at the transmitter and removing the distortions made by the channel. The receiver output is fed to the output transducer, which converts the electric signal to its original form i.e. the message signal.

Destination: The destination is the unit to which the message is communicated.

1.5 MODES OF COMMUNICATION

There are two basic modes of communication:

1. **Broadcasting**, which involves the use of a single powerful transmitter and numerous receivers that are relatively inexpensive to build. Here information-bearing signals flow only in one direction.
2. **Point-to-point communication**, in which the communication process takes place over a link between a single transmitter and a receiver. In this case, there is usually a bidirectional flow of information-bearing signals, which requires the use of a transmitter and receiver at each end of the link.
3. **Multi casting**: It is similar to broadcasting but message transmission is intended for specific receiver not for all receivers.

1.5.1 Communication Technique

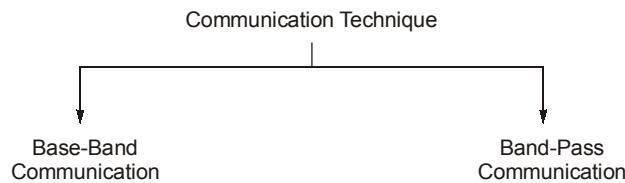

1. **Base Band Communication**: It is generally used for short distance communication. In this type of communication message is directly sent to the receiver without altering its frequency.
2. **Band Pass Communication**: It is used for long distance communication. In this type of communication, the message signal is mixed with another signal called as the carrier signal for the process of transmission. This process of adding a carrier to a signal is called as modulation.

1.5.2 Need of Modulation

1. **To avoid the mixing of signals**

All messages lies within the range of 20 Hz - 20 kHz for speech and music, few MHz for video, so that all signals from the different sources would be inseparable and mixed up. In order to avoid mixing of various signals, it is necessary to translate them all to different portions of the electromagnetic spectrum.

2. **To decrease the length of transmitting and receiving antenna**

For a message at 10 kHz, the antenna length 'l' for practical purposes is equal to $\lambda/4$ (from antenna theory) i.e.,

$$\lambda = \frac{3 \times 10^8}{10 \times 10^3} = 3 \times 10^4 \text{ m} \quad \text{and} \quad l = \frac{\lambda}{4} = \frac{3 \times 10^4}{4} = 7500 \text{ m}$$

An antenna of this size is impractical and for a message signal at 1 MHz

$$\lambda = \frac{3 \times 10^8}{10^6} = 300 \text{ m} \quad \text{and} \quad l = \frac{\lambda}{4} = 75 \text{ m (practicable)}$$

3. **To allow the multiplexing of signals**

By translating all signals from different sources to different carrier frequency, we can multiplex the signals and able to send all signals through a single channel.

4. **To remove the interference**
5. **To improve the quality of reception i.e. increasing the value of S/N ratio**
6. **To increase the range of communication**

1.6 TYPES OF MODULATION

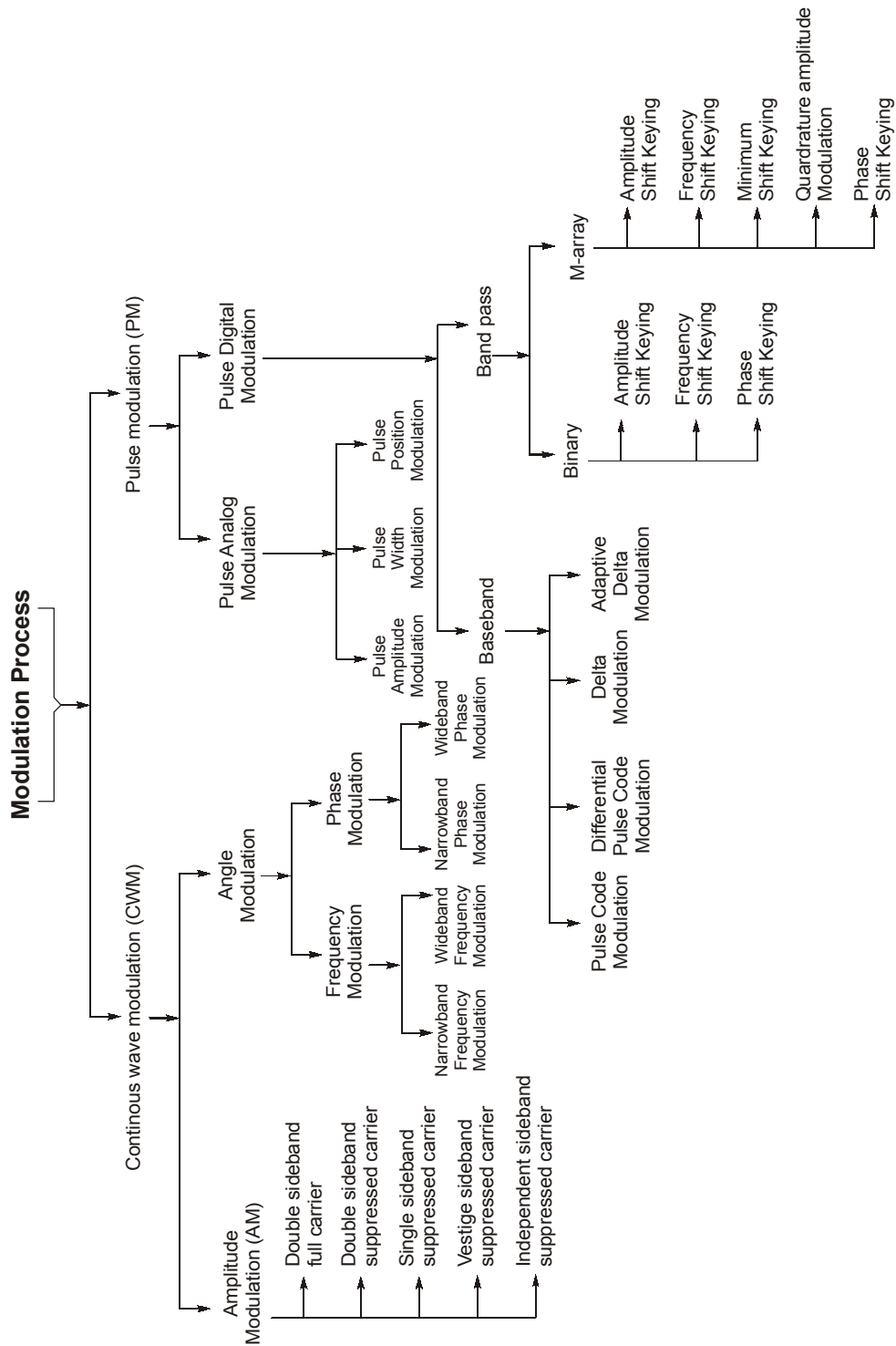

1.7 AN EXAM ORIENTED APPROACH

Communication is a modern technology is undergoing many changes. The main focus of a student should be to single out on optimum path in which he develops a theoretically strong background of the subject while keeping in mind that he should be able to solve questions asked in various exams using the theory they have studied. Focusing on one aspect leads to failure in written exam or in the interview. Thus this book and communication both have the same approach and that is “optimization” and being a communication engineer one should have this approach too.

Frequency (f) range	Wavelength (λ) range	EM Spectrum Nomenclature	Typical Application
30 – 300 Hz	$10^7 - 10^6$ m	Extremely low frequency (ELF)	Power line communication
0.3 – 3 kHz	$10^6 - 10^5$ m	Voice frequency (VF)	Face to face speech, communication intercom
3 – 30 kHz	$10^5 - 10^4$ m	Very low frequency (VLF)	Submarine communication
30 – 300 kHz	$10^4 - 10^3$ m	Low frequency (LF)	Marine communication
0.3 – 3 MHz	$10^3 - 10^2$ m	Medium frequency (MF)	AM broadcasting
3 – 30 MHz	$10^2 - 10^1$ m	High frequency (HF)	Landline telephony
30 – 300 MHz	$10^1 - 10^0$ m	Very high frequency (VHF)	FM broadcasting, TV
0.3 – 3 GHz	$10^0 - 10^{-1}$ m	Ultra high frequency (UHF)	TV, Cellular telephony
3 – 30 GHz	$10^{-1} - 10^{-2}$ m	Super high frequency (SHF)	Microwave oven, radar
30 – 300 GHz	$10^{-2} - 10^{-3}$ m	Extremely high frequency (EHF)	Satellite communication, radar
0.3 – 3 THz	0.1 – 1 mm	Experimental	For all new explorations
3 – 430 THz	100 – 0.7 μm	Infrared	LED, Laser, TV remote
430 – 750 THz	0.7 – 0.4 μm	Visible light	Optical communication
750 – 3000 THz	0.4 – 0.1 μm	Ultraviolet	Medical application
> 3000 THz	< 0.1 μm	X-rays, gamma rays, cosmic rays	Medical application

Table: EM Spectrum

1.8 IMPORTANT FOURIER TRANSFORM

S. No.	$x(t)$	$X(\omega)$	$X(f)$	Comment
1.	$e^{-at} u(t)$	$\frac{1}{a + j\omega}$ $a > 0$	$\frac{1}{a + j(2\pi f)}$	Asymmetric, complex
2.	$e^{at} u(-t)$	$\frac{1}{a - j\omega}$ $a > 0$	$\frac{1}{a - j(2\pi f)}$	Asymmetric, complex
3.	$e^{-a t }$	$\frac{2a}{a^2 + \omega^2}$, $a > 0$	$\frac{2a}{a^2 + (2\pi f)^2}$	Real and even symmetric
4.	$te^{-at} u(t)$	$\frac{1}{(a + j\omega)^2}$, $a > 0$	$\frac{1}{(a + j2\pi f)^2}$	Multiplication of t
5.	$t^n e^{-at} u(t)$	$\frac{n!}{(a + j\omega)^{n+1}}$, $a > 0$	$\frac{n!}{(a + j2\pi f)^{n+1}}$	Multiplication of t^n
6.	$\delta(t)$	1	1	Real and even symmetric

S. No.	$x(t)$	$X(\omega)$	$X(f)$	Comment
7.	A	$2\pi A\delta(\omega)$	$A\delta(f)$	Real and even symmetric
8.	$e^{j\omega_0 t}$	$2\pi\delta(\omega - \omega_0)$	$\delta(f - f_0)$	Frequency shifting
9.	$\cos \omega_0 t$	$\pi[\delta(\omega - \omega_0) + \delta(\omega + \omega_0)]$	$\frac{1}{2}[\delta(f - f_0) + \delta(f + f_0)]$	Used in modulation property
10.	$\sin \omega_0 t$	$j\pi[\delta(\omega + \omega_0) - \delta(\omega - \omega_0)]$	$\frac{j}{2}[\delta(f + f_0) - \delta(f - f_0)]$	Used in modulation property
11.	$u(t)$	$\frac{1}{j\omega} + \pi\delta(\omega)$	$\frac{1}{j2\pi f} + \frac{\delta(f)}{2}$	Unit step function
12.	$\text{sgn}(t)$	$\frac{2}{j\omega}$	$\frac{1}{j\pi f}$	Imaginary and odd symmetric
13.	$\cos \omega_0 t u(t)$	$\frac{\pi}{2}[\delta(\omega - \omega_0) + \delta(\omega + \omega_0)] + \frac{j\omega}{\omega_0^2 - \omega^2}$	$\frac{1}{2}[\delta(f - f_0) + \delta(f + f_0)] + \frac{j2\pi f}{(2\pi f_0)^2 - (2\pi f)^2}$	
14.	$\sin \omega_0 t u(t)$	$j\frac{\pi}{2}[\delta(\omega + \omega_0) - \delta(\omega - \omega_0)] + \frac{\omega_0}{\omega_0^2 - \omega^2}$	$\frac{j}{2}[\delta(f + f_0) - \delta(f - f_0)] + \frac{2\pi f_0}{(2\pi f_0)^2 - (2\pi f)^2}$	
15.	$e^{-at} \sin \omega_0 t u(t)$	$\frac{\omega_0}{(a + j\omega)^2 + \omega_0^2}, a > 0$	$\frac{2\pi f_0}{(a + j2\pi f)^2 + 2\pi f_0^2}, a > 0$	Decaying sin function
16.	$e^{-at} \cos \omega_0 t u(t)$	$\frac{a + j\omega}{(a + j\omega)^2 + \omega_0^2}, a > 0$	$\frac{a + j2\pi f}{(a + j2\pi f)^2 + 2\pi f_0^2}, a > 0$	Decaying cosine function
17.	$\text{rect}(t/\tau)$	$\tau S_a\left(\frac{\omega\tau}{2}\right)$	$\tau \text{sinc}(f\tau)$	Rectangular function
18.	$W \text{sinc}(Wt)$	$\text{rect}\left(\frac{\omega}{2\pi W}\right)$	$\text{rect}\left(\frac{f}{W}\right)$	Sinc function
19.	$\sum_{n=-\infty}^{\infty} \delta(t - nT)$	$\omega_0 \sum_{k=-\infty}^{\infty} \delta(\omega - k\omega_0)$	$f_0 \sum_{k=-\infty}^{\infty} \delta(f - kf_0)$	Sampling function
20.	$e^{-t^2/2\sigma^2}$	$\sigma\sqrt{2\pi}e^{-\sigma^2\omega^2/2}$	$\sigma\sqrt{2\pi}e^{-\sigma^2(2\pi f)^2/2}$	Gaussian signal

1.9 TRANSMISSION OF SIGNALS THROUGH LINEAR TIME-INVARIANT SYSTEMS

A system refers to any physical entity that produces an output signal in response to an input signal. It is customary to define the input signal as the excitation and the output signal as the response. In a linear system, the principle of superposition holds: that is, the response of a linear system to a number of excitation applied simultaneously is equal to the sum of the responses of the system when each excitation is applied individually.

1.9.1 The Time Domain Response

In the time domain, a linear system is usually described in terms of its impulse response. The impulse response of a linear system is the response of the system (with zero initial conditions) to a unit impulse or delta function $\delta(t)$ applied to the input of the system at time $t = 0$.

Suppose that a system described by the impulse response $h(t)$ is subjected to an arbitrary excitation $x(t)$. The resulting response of the system $y(t)$, is defined in terms of the impulse response $h(t)$ by

$$y(t) = \int_{-\infty}^{\infty} x(\tau)h(t - \tau)d\tau$$

Which is called the convolution integral. Equivalently, we may write

$$y(t) = \int_{-\infty}^{\infty} h(\tau)x(t - \tau)d\tau$$

Input = $x(t)$ → LTI system $h(t)$ → Output = $y(t)$
 $y(t) = x(t) * h(t)$

1.9.2 Examining the Convolution Integral

We see that three different time scales are involved: excitation time τ , response time t , and system memory time $t - \tau$. This relation is the basis of time-domain analysis of linear time-invariant systems. The present value of the response of a linear time-invariant system is an integral over the past history of the input signal, weighted according to the impulse response of the system. Thus, the impulse response acts as a memory function of the system.

1.9.3 Frequency Response

Let $X(f)$, $H(f)$, and $Y(f)$ denote the Fourier transforms of the excitation $x(t)$, the impulse response of the system $h(t)$ and the output $y(t)$.

Equivalently, we may write

input, $x(t) \xrightarrow{FT} X(f)$

and output, $y(t) \xrightarrow{FT} Y(f)$

and with a transfer function,

$$h(t) \xrightarrow{FT} H(f)$$

then its input/output relationship is given by:

Input = $x(t)$ → LTI system $h(t)$ → Output = $y(t)$

$$y(t) = x(t) * h(t)$$

apply convolution-time theorem of Fourier transform,

we get,

$$Y(\omega) = X(\omega) H(\omega)$$

∴ $H(\omega) = \frac{Y(\omega)}{X(\omega)}$ = frequency response of continuous time LTI system.

or $H(f) = \frac{Y(f)}{X(f)}$

The new frequency function $H(f)$ is called the transfer function or frequency response of the system. The frequency response of a linear time-invariant system is defined as the ratio of the Fourier transform of the response of the system to the Fourier transform of the excitation applied to the system.

In general, the frequency response $H(f)$ is a complex quantity, so we may express it in the form.

$$H(f) = |H(f)|\exp[j\beta(f)]$$

Where $|H(f)|$ is called the magnitude response, and $\beta(f)$ is the phase response,.

$$|H(f)| = |H(-f)|$$

and

$$\beta(f) = -\beta(-f)$$

That is, the magnitude response $|H(f)|$ of a linear system with real-valued impulse response is an even function of frequency, whereas the phase $\beta(f)$ is an odd function of frequency.

An alternate way of representing the signal in the log scale is

$$\ln H(f) = \alpha(f) + j\beta(f)$$

where

$$\alpha(f) = \ln |H(f)|$$

The function $\alpha(f)$ is called the gain of the system, it is measured in nepers. The phase $\beta(f)$ is measured in radians. Equation indicates that the gain $\alpha(f)$ and phase $\beta(f)$ are, respectively, the real and imaginary parts of the (natural) logarithm of the transfer function $H(f)$.

$$\text{where the gain} = \alpha(f) = 20 \log_{10} |H(f)| \text{ in (db)}$$

1.9.4 Frequency Response of LTI System

Distortionless Transmission

For a distortionless transmission, the output waveform is the exact replica of the input waveform. A delayed output that retains the input waveform is also considered distortionless.

For a delayed transfer function by " t_d ", the system is as below.

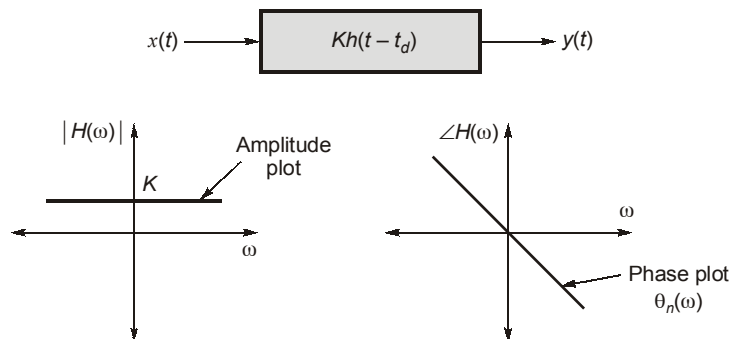

So, if
then,

$$h(t) = \delta(t)$$

$$y(t) = Kx(t - t_d)$$

\Rightarrow

$$Y(\omega) = KX(\omega) e^{-j\omega t_d} \longrightarrow \text{(using time-shifting property)}$$

But we know,

$$Y(\omega) = H(\omega) X(\omega)$$

\therefore

$$H(\omega) = \frac{Y(\omega)}{X(\omega)} = Ke^{-j\omega t_d}$$

\Rightarrow

It is transfer function (T.F.) required for distortionless transmission.



\Rightarrow Phase plot of such functions is odd symmetric.

$\Rightarrow |H(\omega)| = K$ and $\theta_n(\omega) = -\omega t_d$

1.10 IDEAL FILTERS

These filters allow distortionless transmission of a certain band of frequencies and suppresses all the remaining frequencies.

Ideal low-pass filter frequency response and its impulse response

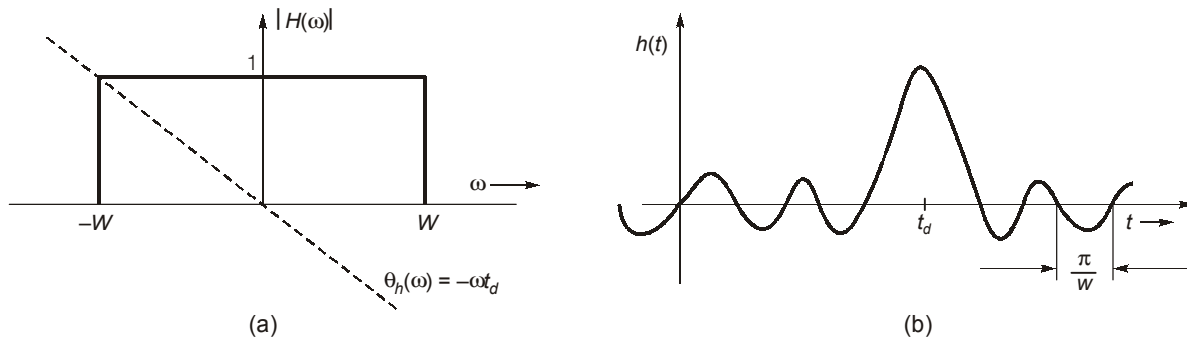

Figure: (a) Frequency response of ideal LPF and (b) impulse response of ideal LPF

Ideal high-pass and band-pass filter frequency response

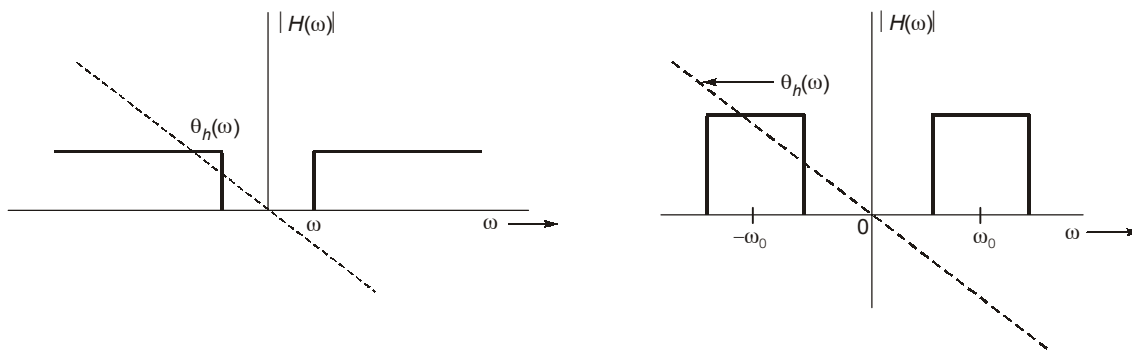
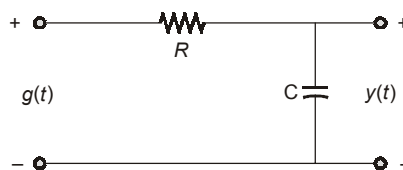

Figure : High-pass filter frequency response

Figure : Band- pass filter frequency response

For a physically realizable system $h(t)$ must be causal, that is $h(t) = 0$ for $t < 0$.

1.10.1 Practical RC Filter And its Response



Transfer Function,

$$H(\omega) = \frac{1}{R + \frac{1}{j\omega C}} = \frac{1}{1 + j\omega RC} = \frac{a}{a + j\omega} \quad \left(a = \frac{1}{RC} \right)$$

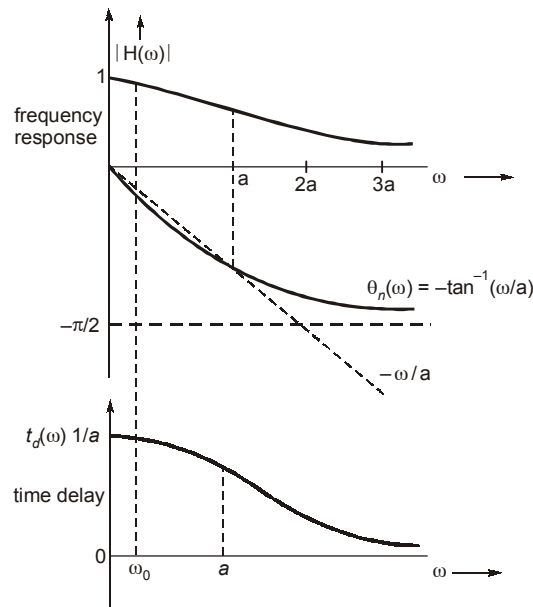

1.11 HILBERT TRANSFORM

In an LTI system the output $y(t)$ can be written as

$$y(t) = x(t) * h(t)$$

where $x(t)$ is the input signal and $h(t)$ is the impulse response of the LTI system.

Now, in frequency domain the equation can be written as

$$Y(f) = X(f) H(f) \quad \text{or} \quad |Y(f)| = |X(f)| |H(f)|$$

and

$$\theta_y(f) = \theta_x(f) + \theta_h(f)$$

If we design a filter with $|H(j\omega)| = 1$, then the above expression will reduce to.

$$|Y(f)| = |X(f)|$$

and

$$\theta_y(f) = \theta_x(f) + \theta_h(f)$$

From our study of Fourier transform, we know that a phase addition is caused by a time delay

\therefore

$$y(t) = x(t - T_d)$$

Now, in this we consider a special case where,

$$\theta_y(f) = \begin{cases} -\frac{\pi}{2} + \theta_x(f) & ; f > 0 \\ \frac{\pi}{2} + \theta_x(f) & ; f < 0 \end{cases}$$

and

$$|Y(f)| = |X(f)| \quad \forall f \neq 0$$

Alternately we can write,

$$H(f) = -j \operatorname{sgn}(f)$$

and

$$-j \operatorname{sgn}(f) \xrightarrow{\text{FT}} \frac{1}{\pi t}$$

$$h(t) = \frac{1}{\pi t}$$

When $x(t)$ is the input to a Hilbert transformer, we denote its output as $\hat{x}(t)$

where,
$$\hat{x}(t) = x(t) * \frac{1}{\pi t} = \frac{1}{\pi} \int_{-\infty}^{\infty} \frac{x(\tau)}{t-\tau} d\tau \quad \text{and} \quad \hat{X}(f) = -j \operatorname{sgn}(f) X(f)$$

$\hat{x}(t)$ is called the Hilbert transform of $x(t)$.

Note: Unlike other transforms, both $x(t)$ and $\hat{x}(t)$ are functions of the same variable (t in our case).

Hilbert Transform (HT) will prove quite useful later on in the study of bandpass signals and single sideband signals. For the present, let us look at some examples of HT.

EXAMPLE : 1.1

Hilbert transform of $\delta(t)$. For $x(t) = \delta(t)$, find Hilbert transform $\hat{x}(t)$.

Solution:

As $\delta(t) \longleftrightarrow 1$, we have

$$F[\hat{\delta}(t)] = -j \operatorname{sgn}(f)$$

$$\Rightarrow \hat{x}(t) = \hat{\delta}(t) = \frac{1}{\pi t}$$

This also establishes the relation,

$$\left[\delta(t) * \frac{1}{\pi t} \right] = \frac{1}{\pi t}$$

EXAMPLE : 1.2

Hilbert transform of a cosine signal. For $x(t) = \cos(2\pi f_0 t)$, find Hilbert transform $\hat{x}(t)$.

Solution:

$$X(f) = \frac{1}{2} [\delta(f - f_0) + \delta(f + f_0)]$$

$$\hat{X}(f) = -j \operatorname{sgn}(f) X(f) \quad \text{i.e.} \quad \hat{X}(f) = \frac{1}{2j} [\delta(f - f_0) - \delta(f + f_0)]$$

That is, $\hat{x}(t) = \sin(2\pi f_0 t)$.

Alternatively,

If $x_1(t) = e^{j2\pi f_0 t}$, then $\hat{x}_1(t) = e^{j(2\pi f_0 t - \pi/2)}$ and if $x_2(t) = e^{-j2\pi f_0 t}$, then $\hat{x}_2(t) = e^{-j(2\pi f_0 t - \pi/2)}$

Hence, $x(t) = \cos(2\pi f_0 t) = \frac{1}{2} [x_1(t) + x_2(t)]$ has $\hat{x}(t)$

$$= \cos\left(\omega_0 t - \frac{\pi}{2}\right) = \sin(\omega_0 t)$$

Similarly, we can show that if $x(t) = \sin(2\pi f_0 t)$, then $\hat{x}(t) = \cos \omega_0 t$.

EXAMPLE : 1.3

A modulated signal is given by

$s(t) = e^{-at} \cos[(\omega_c + \Delta\omega)t] u(t)$, where a , ω_c and $\Delta\omega$ are positive constants, and $\omega_c \gg \Delta\omega$. The complex envelope of $s(t)$ is given by

(a) $\exp(-at) \exp[j(\omega_c + \Delta\omega)t] u(t)$ (b) $\exp(-at) \exp(j\Delta\omega t) u(t)$

(c) $\exp(j\Delta\omega t) \cdot u(t)$ (d) $\exp[j\omega_c + \Delta\omega)t]$



REMEMBER

- The concepts of pre-envelope and complex envelope are just mathematical manipulation to make the analytical study of communication easier they can not exist in real time because they make a time domain signal complex in nature.
- The use of pre-envelope and complex envelope is understood when we want to represent operation performed on certain portion of frequency in time domain. Like if we want to attenuate a single side band by some amount then filter representation helps to express this operation in frequency domain and complex envelope is used to express it in time domain.
- We can compare this concept of pre-envelope and complex envelope with the concept of exponential phasor in electrical engineering used for circuit analysis.

OBJECTIVE
BRAIN TEASERS

- Q.1** A modulated signal is given by,
 $s(t) = m_1(t) \cos(2\pi f_c t) + m_2(t) \sin(2\pi f_c t)$
 where the baseband signal $m_1(t)$ and $m_2(t)$ have bandwidths of 10 kHz and 15 kHz, respectively. The bandwidth of the modulated signal, in kHz, is
 (a) 10 (b) 15
 (c) 25 (d) 30
- Q.2** Let $\delta(t)$ denote the delta function. The value of the integral $\int_{-\infty}^{\infty} \delta(t) \cos\left(\frac{3t}{2}\right) dt$ is
 (a) 1 (b) -1
 (c) 0 (d) $\frac{\pi}{2}$
- Q.3** The trigonometric Fourier series of an even function of time does not have
 (a) the dc term (b) cosine terms
 (c) sine terms (d) odd harmonic terms
- Q.4** The trigonometric Fourier series of a periodic time function can have only
 (a) cosine terms
 (b) sine terms
 (c) cosine and sine terms
 (d) dc and cosine terms
- Q.5** If $f(t)$ is an even function, then what is its Fourier transform $F(j\omega)$?
 (a) $\int_0^{\infty} f(t) \cos(2\omega t) dt$ (b) $2 \int_0^{\infty} f(t) \cos(\omega t) dt$
 (c) $2 \int_0^{\infty} f(t) \sin(\omega t) dt$ (d) $\int_0^{\infty} f(t) \sin(2\omega t) dt$
- Q.6** If the Fourier transform of $f(t)$ is $f(j\omega)$, then what is the Fourier transform of $f(-t)$?
 (a) $f(j\omega)$
 (b) $f(-j\omega)$
 (c) $-F(j\omega)$
 (d) complete conjugate of $f(j\omega)$
- Q.7** The trigonometric Fourier series expansion of an odd function shall have
 (a) only sine terms
 (b) only cosine terms
 (c) odd harmonics of both sine and cosine terms
 (d) none of the these

ANSWERS KEY

1. (d) 2. (a) 3. (c) 4. (c)
 5. (b) 6. (b) 7. (a)

HINTS & EXPLANATIONS

1. (d)

$s(t) = m_1(t) \cdot \cos 2\pi f_c t + m_2(t) \cdot \sin 2\pi f_c t$
Taking Fourier transform,

$$S(f) = \frac{1}{2} [M_1(f - f_c) + M_1(f + f_c)] + \frac{1}{2j} [M_2(f - f_c) - M_2(f + f_c)]$$

$m_1(t)$ and $m_2(t)$ have bandwidths of 10 kHz and 15 kHz respectively, we can assume the frequency spectrum of $m_1(t)$ and $m_2(t)$ as below:

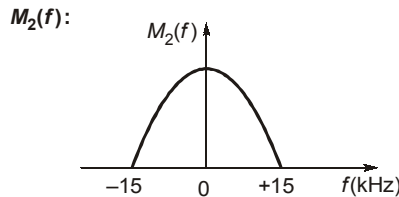
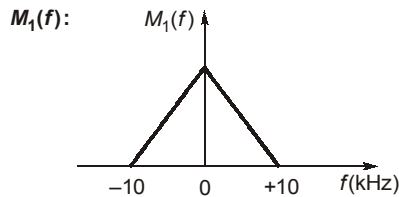

Using above, the frequency spectrum of the modulated signal can be drawn as below:

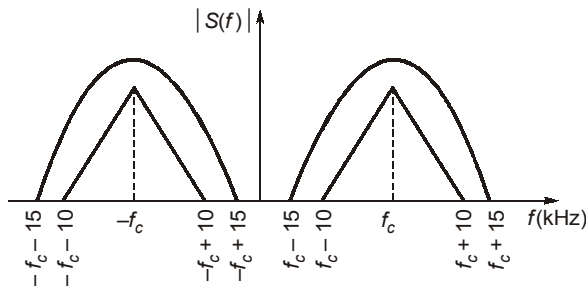

Bandwidth of modulated signal
 $= (f_c + 15) - (f_c - 15) = 30 \text{ kHz}$

2. (a)

Let, $I = \int_{-\infty}^{\infty} \delta(t) \cdot \cos\left(\frac{3t}{2}\right) \cdot dt$

Using the property of impulse function,

$$\int_{-\infty}^{\infty} \delta(t) \cdot x(t) \cdot dt = x(0)$$

Hence, $I = \cos 0^\circ = 1$

3. (c)

For the trigonometric Fourier series,

$$b_n = \frac{2}{T_o} \int_{-T_o/2}^{T_o/2} x(t) \cdot \sin(n\omega_o t) \cdot dt$$

$$b_n = \frac{2}{T_o} \int_{-T_o/2}^0 x(t) \cdot \sin(n\omega_o t) \cdot dt + \frac{2}{T_o} \int_0^{T_o/2} x(t) \cdot \sin(n\omega_o t) \cdot dt$$

In the first integral, substitute $t = -t$.

For an even signal, $x(t) = x(-t)$.

$$b_n = \frac{2}{T_o} \int_{T_o/2}^{T_o/2} x(t) \cdot [-\sin(n\omega_o t)] \cdot dt + \frac{2}{T_o} \int_{T_o/2}^{T_o/2} x(t) \cdot \sin(n\omega_o t) \cdot dt$$

$\Rightarrow b_n = 0$

Hence, the trigonometric Fourier series of an even function does not have sine terms.

4. (c)

The trigonometric Fourier series representation of a periodic signal is given as

$$x(t) = a_0 + \sum_{n=1}^{\infty} (a_n \cos n\omega_o t + b_n \sin n\omega_o t)$$

It can be expressed as

$$x(t) = \sum_{n=0}^{\infty} (a_n \cos n\omega_o t + b_n \sin n\omega_o t)$$

Hence, the trigonometric Fourier series of a periodic time function has cosine and sine terms.

5. (b)

$$F(j\omega) = \int_{-\infty}^{\infty} f(t) \cdot e^{-j\omega t} \cdot dt$$

$$F(j\omega) = \int_{-\infty}^{\infty} f(t) \cdot [\cos \omega t - j \sin \omega t] \cdot dt$$

$$F(j\omega) = \int_{-\infty}^{\infty} f(t) \cos \omega t \cdot dt - j \int_{-\infty}^{\infty} f(t) \cdot \sin \omega t \cdot dt$$

$$F(j\omega) = \int_{-\infty}^0 f(t) \cos \omega t \cdot dt + \int_0^{\infty} f(t) \cos \omega t \cdot dt$$

$$-j \int_{-\infty}^0 f(t) \cdot \sin \omega t \cdot dt - j \int_0^{\infty} f(t) \sin \omega t \cdot dt$$

Substituting $t = -u$ in first and third integral.
Hence, $dt = -du$.

Since, $f(-t) = f(t)$, we get,

$$F(j\omega) = \int_0^0 f(u) (\cos \omega u) (-du) + \int_0^{\infty} f(t) (\cos \omega t) dt$$

$$-j \int_0^{\infty} f(u) (-\sin \omega u) (-du) - j \int_0^{\infty} f(t) (\sin \omega t) dt$$

$$F(j\omega) = \int_0^{\infty} f(u) (\cos \omega u) \cdot du + \int_0^{\infty} f(t) (\cos \omega t) dt$$

$$+ j \int_0^{\infty} f(u) (\sin \omega u) du - j \int_0^{\infty} f(t) \cdot (\sin \omega t) \cdot dt$$

$$F(j\omega) = 2 \int_0^{\infty} f(t) \cos \omega t \cdot dt$$

6. (b)

$$F[f(-t)] = \int_{-\infty}^{\infty} f(-t) \cdot e^{-j\omega t} \cdot dt$$

$$\text{Let } -t = u \Rightarrow -dt = du$$

$$F[f(-t)] = \int_{\infty}^{-\infty} f(u) \cdot e^{j\omega u} (-du)$$

$$F[f(-t)] = \int_{-\infty}^{\infty} f(u) \cdot e^{-j(-\omega)u} du$$

$$F[f(-t)] = f(-j\omega)$$

7. (a)

For an odd function,

$$a_o = \frac{1}{T} \int_{-T/2}^{T/2} f(t) \cdot dt = 0$$

$$a_n = \frac{2}{T} \int_{-T/2}^{T/2} \underbrace{f(t) \cdot \cos n\omega_o t \cdot dt}_{\text{Odd function}} = 0$$

Since, $a_o = 0$ and $a_n = 0$, therefore the trigonometric Fourier series expansion of an odd signal have only sine terms ($\because b_n \neq 0$).



CONVENTIONAL BRAIN TEASERS

Q.1 For the rectangular pulse shown in the figure below, determine the Fourier Transform of $x(t)$ and sketch the magnitude spectrum with respect to frequency.

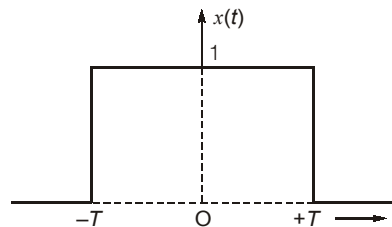

1. (Sol.)

The Fourier transform of signal $x(t)$ is given as

$$X(\omega) = \int_{-\infty}^{\infty} x(t) \cdot e^{-j\omega t} \cdot dt$$

We have,

$$x(t) = \begin{cases} 1 & ; -T \leq t \leq T \\ 0 & ; \text{otherwise} \end{cases}$$

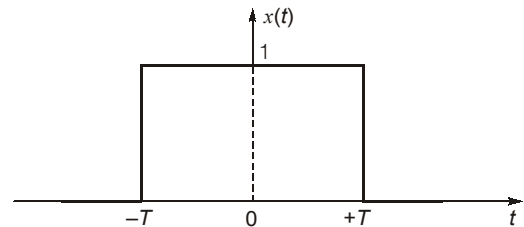

Hence,

$$X(\omega) = \int_{-T}^T e^{-j\omega t} \cdot dt = -\frac{1}{j\omega} X[e^{-j\omega t}]_{-T}^T = \frac{e^{j\omega T} - e^{-j\omega T}}{j\omega} = \frac{2\sin(\omega T)}{\omega} = 2T \left[\frac{\sin(\omega T)}{\omega T} \right]$$

$$X(\omega) = 2TS_a(\omega T)$$

Magnitude spectrum: The zero crossings occur at

$$\omega T = 0, \pm\pi, \pm 2\pi \dots$$

$$\omega = 0, \pm \pi/T, \pm 2\pi/T \dots$$

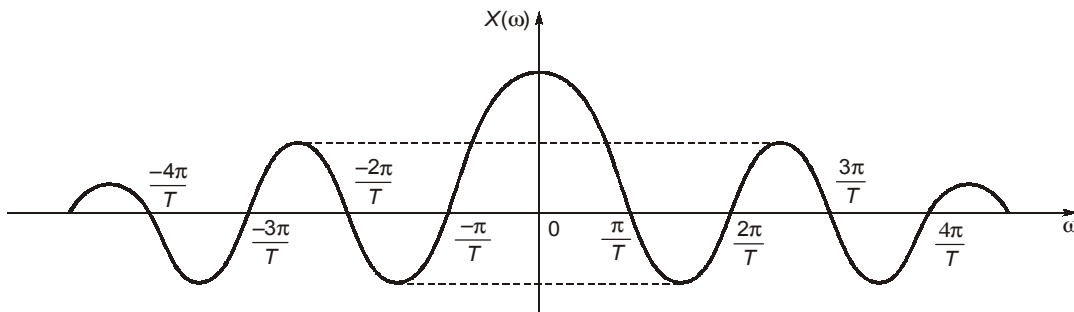

Q.2 Using time shifting and time differentiation properties, find the Fourier transform of the trapezoidal signal shown.

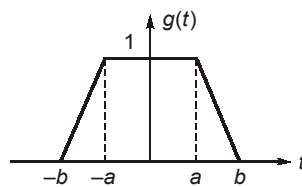

2. (Sol.)

The given signal $g(t)$ can be expressed as:

$$g(t) = \begin{cases} \frac{t+b}{b-a} & \text{for } -b \leq t < -a \\ 1 & \text{for } -a \leq t \leq a \\ \frac{-t+b}{b-a} & \text{for } a < t \leq b \end{cases}$$

Differentiating $g(t)$ w.r.t. time,

$$\frac{dg(t)}{dt} = \begin{cases} \frac{1}{b-a} & ; \text{ for } -b \leq t < -a \\ 0 & ; \text{ for } -a \leq t \leq a \\ \frac{-1}{b-a} & ; \text{ for } a < t \leq b \end{cases}$$

$$\therefore \frac{dg(t)}{dt} = \frac{1}{(b-a)} u(t+b) - \frac{1}{(b-a)} u(t+a) - \frac{1}{(b-a)} u(t-a) + \frac{1}{(b-a)} u(t-b)$$

Differentiating again w.r.t. t ,

$$\frac{d^2g(t)}{dt^2} = \frac{1}{(b-a)} [\delta(t+b) - \delta(t+a) - \delta(t-a) + \delta(t-b)]$$

Taking Fourier transform,

$$F \left[\frac{d^2g(t)}{dt^2} \right] = \frac{1}{(b-a)} [e^{j\omega b} - e^{j\omega a} - e^{-j\omega a} + e^{-j\omega b}]$$